

## Sleeve-All® Sleeve Anchor

Sleeve-All expanding anchors are pre-assembled, expanding sleeve anchors for use in all types of solid base materials. This anchor is available in acorn, hex, rod coupler, flat or round head style for a wide range of applications.

**Codes:** Factory Mutual 3017082, 3026805 and 3029959 ( $\frac{3}{8}$ " –  $\frac{1}{2}$ " diameter); Underwriters Laboratories File Ex3605 ( $\frac{3}{8}$ " –  $\frac{3}{4}$ " diameter); Multiple DOT listings; meets the requirements of Federal Specification A-A-1922A

**Material:** Carbon steel or stainless steel

**Coating:** Carbon steel anchors are zinc plated

## Installation

1. Drill a hole in the base material using a carbide drill bit the same diameter as the nominal diameter of the anchor to be installed.
2. Drill the hole to the specified embedment depth, and blow it clean using compressed air. (Overhead installations need not be blown clean.) Alternatively, drill the hole deep enough to accommodate embedment depth and the dust from drilling.
3. Place the anchor in the fixture, and drive it into the hole until the washer and nut are tight against the fixture.
4. Tighten to required installation torque.

**Caution:** Oversized holes will make it difficult to set the anchor and will reduce the anchor's load capacity.



## Installation Sequence

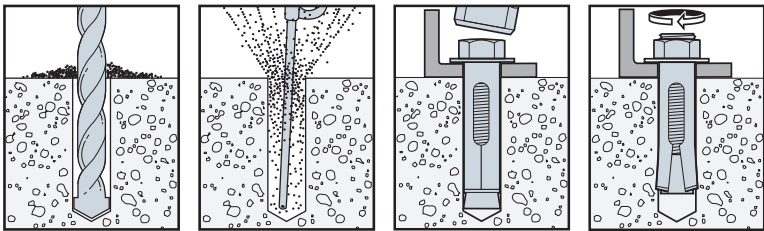

3/8" diameter anchor data for CIP and CMU is bubbled for convenience

\*CIP See Pages 71,72,138,140

\*CMU See Pages 71,72,138,139

## Sleeve-All® Sleeve Anchor

## Material Specifications

Anchor Component	Zinc-Plated Carbon Steel	304 Stainless Steel
Anchor body	Material meets minimum 50,000 psi tensile	Type 304
Sleeve	SAE J403, Grade 1008 cold-rolled steel	Type 304
Nut	Commercial Grade, meets requirements of ASTM A563 Grade A	Type 304
Washer	SAE J403, Grade 1008/1010 cold-rolled steel	Type 304

## Sleeve-All Anchor Installation Data

Sleeve-All Diameter (in.)	1/4	5/16	3/8	1/2	5/8	3/4
Installation torque (ft.-lb.)	5	8	15	25	50	90
Drill bit size (in.)	1/4	5/16	3/8	1/2	5/8	3/4
Wrench size <sup>1</sup> (in.)	3/8	7/16	1/2	9/16	3/4	15/16
Wrench size for coupler nut (in.)			1/2	5/8	3/4	—

1. Applies to acorn- and hex-head configurations only.

## Sleeve-All Anchor Product Data — Stainless Steel

Size (in.)	Model No.	Head Style	Bolt Diameter – Threads per inch	Max. Fixture Thickness (in.)	Quantity	
					Box	Carton
3/8 x 1 7/8	SL37178HSS	Hex head	5/16-18	3/8	50	250
3/8 x 3	SL37300HSS			1 1/2	50	200
1/2 x 3	SL50300HSS		3/8-16	3/4	25	100
1/2 x 4	SL50400HSS			1 3/4	25	100

## Sleeve-All Anchor (with rod coupler) Product Data — Zinc-Plated Carbon Steel

Size (in.)	Model No.	Accepts Rod Diameter (in.)	Wrench Size (in.)	Quantity	
				Box	Carton
3/8 x 1 7/8	SL37178C	3/8	1/2	50	200
1/2 x 2 1/4	SL50214C	1/2	5/8	25	100
5/8 x 2 1/4	SL62214C	5/8	3/4	20	80

## Sleeve-All® Sleeve Anchor

## Sleeve-All Anchor Product Data — Zinc-Plated Carbon Steel

Size (in.)	Model No.	Head Style	Bolt Diameter – Threads per inch	Max. Fixture Thickness (in.)	Quantity		
					Box	Carton	
¼ x 1¾	SL25138A	Acorn head	¾-24	¼	100	500	
¼ x 2¼	SL25214A			1½	100	500	
⅝ <sub>16</sub> x 1½	SL31112H	Hex head	¼-20	⅜	100	500	
⅝ <sub>16</sub> x 2½	SL31212H			1½	50	250	
⅝ <sub>16</sub> x 1¾	SL37178H		⅝-18	⅜	50	250	
⅝ <sub>16</sub> x 3	SL37300H			1½	50	200	
⅝ <sub>16</sub> x 4	SL37400H			2¼	50	200	
½ x 2¼	SL50214H		¾-16	½	50	200	
½ x 3	SL50300H			¾	25	100	
½ x 4	SL50400H			1¾	25	100	
½ x 6	SL50600H			3¾	20	80	
⅝ <sub>16</sub> x 2¼	SL62214H		½-13	½	25	100	
⅝ <sub>16</sub> x 3	SL62300H			¾	20	80	
⅝ <sub>16</sub> x 4¼	SL62414H			1½	10	40	
⅝ <sub>16</sub> x 6	SL62600H			3¼	10	40	
¾ x 2½	SL75212H			⅝-11	½	10	40
¾ x 4¼	SL75414H				¾	10	40
¾ x 6¼	SL75614H		2¾		5	20	
¼ x 2	SL25200PF		¾-24	¾	100	500	
¼ x 3	SL25300PF			1⅞	50	250	
⅝ <sub>16</sub> x 2½	SL31212PF		¼-20	1½	50	250	
⅝ <sub>16</sub> x 3½	SL31312PF			2½	50	250	
⅝ <sub>16</sub> x 2¾	SL37234PF	Phillips flat head	⅝-18	1¼	50	200	
⅝ <sub>16</sub> x 4	SL37400PF			2½	50	200	
⅝ <sub>16</sub> x 5	SL37500PF			3½	50	200	
⅝ <sub>16</sub> x 6	SL37600PF			4½	50	200	
¼ x 2¾	SL25234R	Round head	¾-24	¾	50	250	

Length Identification Head Marks on Sleeve-All Anchors  
(corresponds to length of anchor — inches)

Mark	A	B	C	D	E	F	G	H	I	J	K	L	M	N	O	P	Q	R	S	T	U	V	W	X	Y	Z
From	1½	2	2½	3	3½	4	4½	5	5½	6	6½	7	7½	8	8½	9	9½	10	11	12	13	14	15	16	17	18
Up To But Not Including	2	2½	3	3½	4	4½	5	5½	6	6½	7	7½	8	8½	9	9½	10	11	12	13	14	15	16	17	18	19

# Sleeve-All® Design Information — Concrete and Masonry

Mechanical Anchors

Allowable Tension and Shear Loads for Sleeve-All in Normal-Weight Concrete

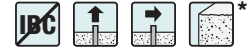

Size in. (mm)	Embed. Depth in. (mm)	Critical Edge Dist. in. (mm)	Critical Spacing Dist. in. (mm)	Tension Load						Shear Load			Install. Torque ft.-lb. (N-m)
				$f'_c \geq 2,000$ psi (13.8 MPa) Concrete			$f'_c \geq 4,000$ psi (27.6 MPa) Concrete			$f'_c \geq 2,000$ psi (13.8 MPa) Concrete			
				Ultimate lb. (kN)	Std. Dev. lb. (kN)	Allow. lb. (kN)	Ultimate lb. (kN)	Std. Dev. lb. (kN)	Allow. lb. (kN)	Ultimate lb. (kN)	Std. Dev. lb. (kN)	Allow. lb. (kN)	
1/4 (6.4)	1 1/8 (29)	2 1/2 (64)	4 1/2 (114)	880 (3.9)	94 (0.4)	220 (1.0)	1,320 (5.9)	189 (0.8)	330 (1.5)	1,440 (6.4)	90 (0.4)	360 (1.6)	5 (7)
5/16 (7.9)	1 (25)	3 3/8 (79)	5 3/4 (146)	930 (4.1)	201 (0.9)	230 (1.0)	1,095 (4.9)	118 (0.5)	275 (1.2)	1,480 (6.6)	264 (1.2)	370 (1.6)	8 (11)
	1 7/16 (37)	3 3/8 (79)	5 3/4 (146)	1,120 (5.0)	113 (0.5)	280 (1.2)	1,320 (5.9)	350 (1.6)	330 (1.5)	2,160 (9.6)	113 (0.5)	540 (2.4)	8 (11)
3/8 (9.5)	1 1/2 (38)	3 3/4 (95)	6 (152)	1,600 (7.1)	294 (1.3)	400 (1.8)	2,680 (11.9)	450 (2.0)	670 (3.0)	3,080 (13.7)	223 (1.0)	770 (3.4)	15 (20)
1/2 (12.7)	1 3/4 (45)	5 (127)	9 (229)	2,900 (12.9)	369 (1.6)	725 (3.2)	3,480 (15.5)	529 (2.4)	870 (3.9)	4,250 (18.9)	659 (2.9)	1,060 (4.7)	25 (34)
	2 1/4 (57)	5 (127)	9 (229)	3,160 (14.1)	254 (1.1)	790 (3.5)	4,760 (21.2)	485 (2.2)	1,190 (5.3)	5,000 (22.2)	473 (2.1)	1,250 (5.6)	25 (34)
5/8 (15.9)	1 3/4 (45)	6 1/4 (159)	11 (279)	3,200 (14.2)	588 (2.6)	800 (3.6)	3,825 (17.0)	243 (1.1)	955 (4.2)	4,625 (20.6)	747 (3.3)	1,155 (5.1)	50 (68)
	2 3/4 (70)	6 1/4 (159)	11 (279)	4,200 (18.7)	681 (3.0)	1,050 (4.7)	6,160 (27.4)	1,772 (7.9)	1,540 (6.9)	8,520 (37.9)	713 (3.2)	2,130 (9.5)	50 (68)
3/4 (19.1)	2 (51)	7 1/2 (191)	13 1/2 (343)	3,200 (14.2)	588 (2.6)	800 (3.6)	4,465 (19.9)	1,017 (4.5)	1,115 (5.0)	5,080 (22.6)	771 (3.4)	1,270 (5.6)	90 (122)
	3 3/8 (86)	7 1/2 (191)	13 1/2 (343)	6,400 (28.5)	665 (3.0)	1,600 (7.1)	9,520 (42.3)	674 (3.0)	2,380 (10.6)	10,040 (44.7)	955 (4.2)	2,510 (11.2)	90 (122)

- The tabulated allowable loads are based on a safety factor of 4.0.
- Allowable loads may not be increased for short-term loading due to wind or seismic forces.
- Refer to allowable load-adjustment factors for spacing and edge distance on p. 140.
- Drill bit diameter used in base material corresponds to nominal anchor diameter.
- Allowable tension loads may be linearly interpolated between concrete strengths listed.
- The minimum concrete thickness is 1 1/2 times the embedment depth.

Allowable Tension and Shear Loads for 3/8" Sleeve-All in Grout-Filled CMU (Anchor Installed in Horizontal Mortar Joint or Face Shell)



Size in. (mm)	Embed. Depth in. (mm)	Min. Edge Dist. in. (mm)	Min. End Dist. in. (mm)	Min. Spacing in. (mm)	Tension Load		Shear Load		Install. Torque ft.-lb. (N-m)
					Ultimate lb. (kN)	Allow. lb. (kN)	Ultimate lb. (kN)	Allow. lb. (kN)	
3/8 (9.5)	1 1/2 (38)	16 (406)	16 (406)	24 (610)	2,000 (8.9)	400 (1.8)	2,300 (10.2)	460 (2.0)	15 (20)

See footnotes on p. 139.

# Sleeve-All® Design Information — Concrete and Masonry



Allowable Tension and Shear Loads for Sleeve-All in Grout-Filled CMU

Size in. (mm)	Embed. Depth in. (mm)	Min. Edge Dist. in. (mm)	Min. End Dist. in. (mm)	Min. Spacing in. (mm)	Tension Load		Shear Load		Install. Torque ft.-lb. (N-m)
					Ultimate lb. (kN)	Allow. lb. (kN)	Ultimate lb. (kN)	Allow. lb. (kN)	
<b>Anchor Installed in a Single Face Shell</b>									
3/8 (9.5)	1 1/2 (38)	12 (305)	12 (305)	24 (610)	1,746 (7.8)	350 (1.6)	2,871 (12.8)	575 (2.6)	15 (20)
1/2 (12.7)	2 1/4 (57)	12 (305)	12 (305)	24 (610)	3,304 (15.1)	675 (3.0)	5,670 (25.2)	1,135 (5.0)	25 (34)
5/8 (15.9)	2 3/4 (70)	12 (305)	12 (305)	24 (610)	3,970 (17.7)	795 (3.5)	8,171 (36.3)	1,635 (7.3)	50 (68)
3/4 (19.1)	3 3/8 (86)	12 (305)	12 (305)	24 (610)	6,395 (28.4)	1,280 (5.7)	12,386 (55.1)	2,475 (11.0)	90 (122)
<b>Anchor Installed in Mortar "T" Joint</b>									
3/8 (9.5)	1 1/2 (38)	8 (203)	8 (203)	24 (610)	1,927 (8.6)	385 (1.7)	3,436 (15.3)	685 (3.0)	15 (20)
1/2 (12.7)	2 1/4 (57)	8 (203)	8 (203)	24 (610)	3,849 (17.1)	770 (3.4)	5,856 (26.0)	1,170 (5.2)	25 (34)
5/8 (15.9)	2 3/4 (70)	8 (203)	8 (203)	24 (610)	4,625 (20.6)	925 (4.1)	7,040 (31.3)	1,410 (6.3)	50 (68)
3/4 (19.1)	3 3/8 (86)	8 (203)	8 (203)	24 (610)	5,483 (24.4)	1,095 (4.9)	7,869 (35.0)	1,575 (7.0)	90 (122)

- The tabulated allowable loads are based on a safety factor of 5.0.
- Listed loads may be applied to installations through a face shell with the following placement guidelines:
  - Minimum 3" from vertical mortar joint.
  - Minimum 1" from vertical cell centerline.
- Values for 6"- and 8"-wide concrete masonry units (CMU) with a minimum specified compressive strength of masonry,  $f_m$ , at 28 days is 1,500 psi.
- Embedment depth is measured from the outside face of the concrete masonry unit.
- Drill bit diameter used in base material corresponds to nominal anchor diameter.

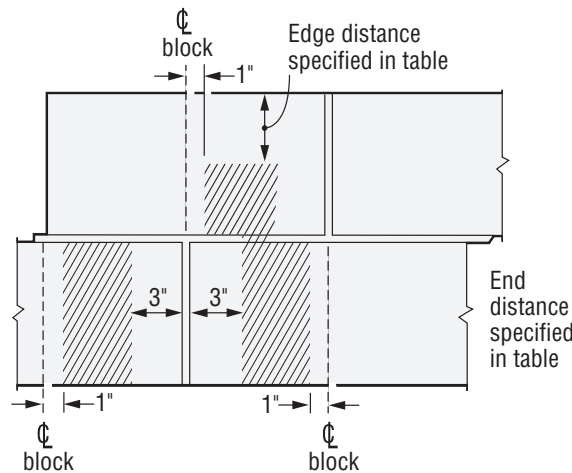

**Face Shell Installation**  
Allowable anchor placement in grout-filled CMU shown by shaded areas.

\* See p. 12 for an explanation of the load table icons.

# Sleeve-All® Design Information — Concrete

## Allowable Load-Adjustment Factors for Sleeve-All Anchors in Normal-Weight Concrete: Edge Distance and Spacing, Tension and Shear Loads

### How to use these charts:

- The following tables are for reduced edge distance and spacing.
- Locate the anchor size to be used for either a tension and/or shear load application.
- Locate the edge distance ( $c_{act}$ ) or spacing ( $s_{act}$ ) at which the anchor is to be installed.
- The load adjustment factor ( $f_c$  or  $f_s$ ) is the intersection of the row and column.
- Multiply the allowable load by the applicable load adjustment factor.
- Reduction factors for multiple edges or spacing are multiplied together.

### Edge Distance Tension ( $f_c$ )

Edge Dist. $c_{act}$ (in.)	Size	1/4	5/16	3/8	1/2	5/8	3/4
	$c_{cr}$	2 1/2	3 1/8	3 3/4	5	6 1/4	7 1/2
	$c_{min}$	1 1/4	1 9/16	1 7/8	2 1/2	3 1/8	3 3/4
	$f_{cmin}$	0.60	0.60	0.60	0.60	0.60	0.60
1 1/4		0.60					
1 1/2		0.68					
1 9/16		0.70	0.60				
1 7/8		0.80	0.68	0.60			
2		0.84	0.71	0.63			
2 1/2		1.00	0.84	0.73	0.60		
3			0.97	0.84	0.68		
3 1/8			1.00	0.87	0.70	0.60	
3 1/2				0.95	0.76	0.65	
3 3/4				1.00	0.80	0.68	0.60
4					0.84	0.71	0.63
4 1/2					0.92	0.78	0.68
5					1.00	0.84	0.73
5 1/2						0.90	0.79
6						0.97	0.84
6 1/4						1.00	0.87
6 1/2							0.89
7							0.95
7 1/2							1.00

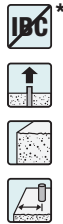

### Spacing Tension and Shear ( $f_s$ )

$s_{act}$ (in.)	Size	1/4	5/16	3/8	1/2	5/8	3/4
	$s_{cr}$	4 1/2	5 3/8	6	9	11	13 1/2
	$s_{min}$	2 1/4	2 7/8	3	4 1/2	5 1/2	6 3/4
	$f_{smin}$	0.50	0.50	0.50	0.50	0.50	0.50
2 1/4		0.50					
2 1/2		0.56					
2 7/8		0.64	0.50				
3		0.67	0.52	0.50			
3 1/2		0.78	0.67	0.58			
4		0.89	0.70	0.67			
4 1/2		1.00	0.78	0.75	0.50		
5			0.88	0.83	0.56		
5 1/2			0.96	0.92	0.61	0.50	
5 3/4			1.00	0.96	0.64	0.52	
6				1.00	0.67	0.55	
6 1/2					0.72	0.59	
6 3/4					0.75	0.61	0.50
7					0.78	0.64	0.52
8					0.89	0.73	0.59
9					1.00	0.82	0.67
10						0.91	0.74
11						1.00	0.81
12							0.89
13							0.96
13 1/2							1.00



See footnotes below.

### Edge Distance Shear ( $f_s$ )

Edge Dist. $c_{act}$ (in.)	Size	1/4	5/16	3/8	1/2	5/8	3/4
	$c_{cr}$	2 1/2	3 1/8	3 3/4	5	6 1/4	7 1/2
	$c_{min}$	1 1/4	1 9/16	1 7/8	2 1/2	3 1/8	3 3/4
	$f_{cmin}$	0.30	0.30	0.30	0.30	0.30	0.30
1 1/4		0.30					
1 1/2		0.44					
1 9/16		0.48	0.30				
1 7/8		0.65	0.44	0.30			
2		0.72	0.50	0.35			
2 1/2		1.00	0.72	0.53	0.30		
3			0.94	0.72	0.44		
3 1/8			1.00	0.77	0.48	0.30	
3 1/2				0.91	0.58	0.38	
3 3/4				1.00	0.65	0.44	0.30
4					0.72	0.50	0.35
4 1/2					0.86	0.61	0.44
5					1.00	0.72	0.53
5 1/2						0.83	0.63
6						0.94	0.72
6 1/4						1.00	0.77
6 1/2							0.81
7							0.91
7 1/2							1.00

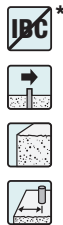

- E = Embedment depth (inches).
- $s_{act}$  = actual spacing distance at which anchors are installed (inches).
- $s_{cr}$  = critical spacing distance for 100% load (inches).
- $s_{min}$  = minimum spacing distance for reduced load (inches).
- $f_s$  = adjustment factor for allowable load at actual spacing distance.
- $f_{scr}$  = adjustment factor for allowable load at critical spacing distance.  $f_{scr}$  is always = 1.00.
- $f_{smin}$  = adjustment factor for allowable load at minimum spacing distance.
- $f_s = f_{smin} + [(1 - f_{smin})(s_{act} - s_{min}) / (s_{cr} - s_{min})]$ .

- $c_{act}$  = actual edge distance at which anchor is installed (inches).
- $c_{cr}$  = critical edge distance for 100% load (inches).
- $c_{min}$  = minimum edge distance for reduced load (inches).
- $f_c$  = adjustment factor for allowable load at actual edge distance.
- $f_{ccr}$  = adjustment factor for allowable load at critical edge distance.  $f_{ccr}$  is always = 1.00.
- $f_{cmin}$  = adjustment factor for allowable load at minimum edge distance.
- $f_c = f_{cmin} + [(1 - f_{cmin})(c_{act} - c_{min}) / (c_{cr} - c_{min})]$ .

\* See p. 12 for an explanation of the load table icons.